

TABLE OF CONTENTS

SECTION I:	Purpose, Scope and Authority	3
SECTION II:	Definitions	4
SECTION III:	Water Use Regulation	
A.	Mooring Privileges and Mooring Space	6
B.	Registration of Watercraft	6
C.	Registration Regulations	9
D.	Launching of Watercraft.....	11
E.	Operator's Requirements.....	11
F.	Equipment.....	12
G.	Lighting Regulations	13
H.	Navigation Rules.....	14
I.	Negligent Operation.....	15
J.	Boating While Intoxicated (BWI)	16
K.	Speed Limits	16
L.	Official Water Traffic Control Devices and Shoreline Buoys	17
M.	Personal Water Craft (PWC).....	17
N.	Water Skiing	19
O.	Swimming	23
P.	Fishing	23
Q.	Miscellaneous	24
SECTION IV:	Use of Other Common Areas	
A.	General Rules.....	26
B.	Rules Relating to Dock Construction and Usage	28
C.	Use of Right of Way Rules.....	34
D.	Use of Parkway and Pathways	35
E.	Miscellaneous	37
F.	Suspensions of Lake Privileges	37
G.	Appeals to Violations	37
SECTION V:	Enforcement of LLA Rules and Regulations	
A.	Water Patrol Enforcement, Citations and Points.....	38
B.	Suspension of Lake Privileges.....	39
C.	Appeals to Violations, Decisions, and Suspensions	39
APPENDIX A:	Placement of Decals	
A.	Lot and Block.....	40
B.	Registration Sticker.....	40

C.	Number and Decal Placement	40
APPENDIX B:	Suspension of Lake Privileges	41
APPENDIX C:	Ski Club Jump Rules	43
APPENDIX D:	Ski Club Slalom Course Rules	44
APPENDIX E:	Shared Dock Agreement	45
APPENDIX F:	Holiday Lake Use Rules	46

SECTION I: PURPOSE, SCOPE AND AUTHORITY

These regulations are promulgated by the Board of Directors of the Lake Lotawana Association Inc. pursuant to the Association By-Laws, applicable restrictive Covenants, and Judgments of the Circuit Court of Jackson County, Missouri, in order to promote and protect the health, safety and general welfare of the residents of Lake Lotawana who are members of the Association and to facilitate the use of commonly owned assets at Lake Lotawana, Missouri.

These provisions are applicable to all members, their families, guests, Renters and others owning or residing on private property or utilizing the Lake, common ground and amenities within the Covenant boundaries of Lake Lotawana

These rules were passed by the Board of Directors on May 11, 1999, have been amended as noted, and supersede all previously enacted rules.

SECTION II: DEFINITIONS

1. **Association:** Shall mean and refer to the Lake Lotawana Association, Inc.
2. **Boat or Watercraft:** Shall mean every vessel capable of traveling on water and carrying property or one or more persons including but not limited to sailboats, motor boats, row boats, jet skis, rafts, canoes, kayaks, sail surfboards, paddle boats or any other vessel.
3. **Common Area:** Shall mean the Lake, roadways, parkways, and pathways located in the Subdivision.
4. **Cove:** A small bay or bay-like recess in a shoreline, as designated by an official water traffic control device.
5. **Dock:** A man made structure, either floating or supported by the Lake bottom, attached to the Lake shore and used to facilitate use of the Lake.
6. **Lake:** The entire body of water known as "Lake Lotawana" located within the boundaries of the Subdivision.
7. **Official Water Traffic Control Devices:** All signs, buoys, markers and devices placed by the Association, for the purpose of regulating, warning or guiding water traffic.
8. **Operator:** A person who drives or is in actual physical control of a Watercraft.
9. **Owner:** The sole person, on file at the Association office, designated to serve as the representative for their property in dealings with the Lake Lotawana Association.
10. **Parkway:** Shall mean the strip of ground owned by the Association between the Lake and the platted lots in the Subdivision.
11. **Pathway:** A narrow strip of ground owned by the Association connecting the Parkway to the roadways, provided in the Lake Lotawana plats and used for access to the Lake by lot Owners as shown on the recorded plats of the Subdivision.
12. **Personal Water Craft (PWC):** A motorized vessel designed to be operated by a single person sitting, standing or kneeling on, as opposed to in, the vessel including by way of description but not limitation, jet skis, wave-runners, sea-doo's and similar vessels.
13. **Pontoon Boat:** Power craft consisting of a deck supported by two or more pontoons.
14. **Power craft:** Motorized Watercraft.
15. **Renter or Lessee:** A person who rents or leases and who possesses and uses (without Ownership) real property within the boundaries of the Subdivision.

16. **Right-Of-Way:** The right of one Watercraft to proceed in preference to another Watercraft.
17. **Roadway:** That portion of the Subdivision specifically set aside in the plats of Lake Lotawana for vehicular use.
18. **Shore Station:** A standalone lift used for lifting and storing Watercraft.
19. **Family or Single Family:** Any member of the immediate family of the responsible property Owner and their spouse to only include their: grandparent(s), parent(s), spouse(s), son and daughter in law(s), child(ren) and grandchild(ren).
20. **Slow No-Wake Speed:** The slowest speed at which a Watercraft will move through the water while being able to maintain course and create only a minimal wake.
21. **Subdivision:** Shall mean and refer to all real estate within the Lake Lotawana plats subject to regulation and control by the Association because of any Restrictive Covenant or Court Order.
22. **Water Patrol Officer:** An individual employed or appointed by the Lake Lotawana Association, who holds the authority to enforce, report and make record of violations of the water use regulations of the Lake Lotawana Association.
23. **Water Ski:** Shall include all apparatus designed to facilitate an individual's movement through water when towed by a boat.
24. **Violation Points:** Included herein subsequent to the rules is the maximum number of points to be assessed for a violation of the specified rule.

Gender, Number and Tense: When the context hereof requires, the gender of all words shall include the masculine, feminine, and neuter; the number of all words shall include the singular and plural and the tense shall include present and past.

SECTION III:

WATER USE REGULATION

A. MOORING PRIVILEGES AND MOORING SPACE:

1. All boats, Watercraft lifts, Docks shall be registered with the Lake Lotawana Association by May 1st of each year. The registration shall be in effect for one calendar year. The registration certificate is a revocable permit, subject to the Watercraft Owner's compliance with water use rules and regulations.
2. In the event property is rented or leased, the recorded title holder of any real property within the Subdivision relinquishes all right to register Watercraft to that property. The Renter and Owner shall complete a Rental Agreement, in a form set by the Association, in order for the Renter to obtain a registration for a boat, Dock or Watercraft lift.
3. No unregistered Watercraft, Watercraft lift or Dock shall be placed on the Lake (6 pts.).
4. No Watercraft, first registered *after* 1997, shall be registered to a lot, unless the lot has constructed on it a structure that complies with all city codes, including restroom facilities.
5. Vendor permits: The Association may issue special temporary permits for boats used in Lakeside services for residents on such terms as the Association in its sole discretion deems appropriate

B. REGISTRATION OF WATERCRAFT:

Prior to use on the water, all Watercraft on Watercraft lifts, Docks, Lake and common area shall be registered with the Lake Lotawana Association by May 1st of each year by the designated Owner, Renter or Lessee at Lake Lotawana. Any property Owner, Renter or Lessee wishing for the first time to register a Watercraft shall pass a written, open book test of the Rules and Regulations of Lake Lotawana with 80% accuracy or better to obtain a Watercraft registration sticker for said Watercraft. The registration shall be in effect for one calendar year. The registration certificate is a revocable permit, subject to the Watercraft Owner's compliance with water use rules and regulations. The following are required to obtain a Registration Certificate:

1. Completion of an annual Watercraft registration application.
2. Payment of the designated annual fee for each Watercraft.
3. Proof of Ownership of the Watercraft with a title, bill of sale, signed statement of Watercraft Ownership, or other documents demonstrating Ownership.

4. Proof of liability insurance in the amount of \$300,000.00 minimum for each power craft and \$100,000.00 minimum for each non-power craft. Umbrella insurance policies are acceptable in conjunction with a base boat or homeowner's policy. Year, manufacturer and type must be listed on policy.
5. Proof of adequate mooring/Docking space.
6. Payment of all sums due the Association.
7. Certificate of inspection from the ASSOCIATION.
8. Compliance with the following **Watercraft Limitations** herein.
 - a. The following are numerical limitations on Watercraft registrations:
 1. **Personal Watercraft (PWC):**

No homeowner shall register more than two PWC's.
 2. **Pontoon Boats:**
 - a. Only one (1) pontoon boat shall be registered per Owner.
 - b. No pontoon boat longer than twenty-eight (28) feet shall be registered or allowed on the Lake.
 3. **Power Boats:**
 - a. No power boat longer than twenty-one (21) feet shall be registered or allowed on the Lake.
 - b. No power boat larger than three thousand one hundred (3,100) pounds in dry unit weight as listed on the manufacturers' website shall be registered or allowed on the Lake.
 - c. Bowsprits, pulpits, bolt-on platforms, rudders, outboard motor brackets are not included in the width or length measurements.
 - d. No boat of any type wider than eight (8) feet six (6) inches shall be registered or allowed on the Lake.

- e. The LLA may choose to keep a list of watercraft models and applicable years of production that do not currently comply with all the restrictions in place in the rulebook, but have been deemed appropriate for use on the lake. This list may only be added to or deleted from with approval from the Board of Directors.

4. Electric Boats:

Watercraft powered 100% by electric motors incapable of exceeding 10 mph shall be 28 feet or less in length.

b. HORSEPOWER LIMITS:

- 1. No person shall operate any Watercraft, which is equipped with any motor or other propulsion machinery, beyond its safe power capacity, as indicated by its manufacturer's OBC recommended horsepower.
- 2. No inboard or inboard-outboard Watercraft (in/io) shall have an engine exceeding three hundred sixty (360) cubic inch displacement.
- 3. No inboard or inboard-outboard (in/io) powered Watercraft shall have a power to weight ratio of more than one (1) to seven (7) (i.e., one (1) horsepower to seven (7) pounds of weight).
- 4. No outboard powered Watercraft shall have a total horsepower over one hundred fifty (150) horsepower.
- 5. No outboard powered Watercraft shall have a power to weight ratio of more than one (1) to ten (10) (i.e., one (1) horsepower to ten (10) pounds of weight).

c. BOAT EXHAUST SYSTEM AND NOISE:

1. EXHAUST SYSTEM:

Power craft shall vent exhaust below the waterline on the boat, as observed when the boat is at rest. Outboard engines of production manufacture having through-propeller or lower-unit exhaust are acceptable. No boat shall have over-the-transom exhaust or through-the-hull exhaust, without having

an underwater exhaust-muzzling system locked in the muzzled position.

2. NOISE:

No power craft shall emit a sound at a level exceeding 85 decibels on an A-weighted scale when measured from a distance of 50 or more feet from the boat.

d. TYPES OF WATERCRAFT AND DEVICES PROHIBITED:

The following are prohibited on Lake Lotawana:

1. Air boat is defined as any craft powered by a propeller or fan rotating in the air instead of the water.
2. No airborne devices, which rise above the surface of the water (i.e., kite, parasail, and parachute), shall be used on the Lake.
3. PWC surfboard type Watercraft.
4. Houseboats defined as any boat, which has toilet facilities, sleeping quarters, galley or any combination thereof (Cuddy Cabins are considered sleeping quarters).
5. Any Watercraft used to advertise a commercial enterprise.
6. Racing motorboats, as classified by the American Power Boat Association.
7. The installation of or deployment of any device to increase wake size.

C. REGISTRATION REGULATIONS:

The following requirements apply to boat registrations. Violations will result in points assessed against Owners as indicated in parenthesis.

1. A Current Registration Decal shall be displayed on all Watercraft before it may be used on the Lake, Watercraft lifts, Docks, or Parkways. Points for this violation are as follows:
 - a. Not correctly displaying decals that have been purchased before the time of violation. (3 pts)
 - b. Neither displaying nor purchasing decals until after time of violation. (6 pts.)
 - c. Operating a watercraft on the Lake for which a sticker has not been purchased. (9 pts.)

Points are not to be compounded based on the number of boats owned.

See Appendix A for placement of decal.

Only the current year sticker shall be visible. (3 pts.).

2. Temporary Watercraft Permit: A property Owner, Renter or Lessee may obtain, at the Association office, a two-hour permit, in order to place a Watercraft on the Lake, for purposes of testing or demonstrating a Watercraft being considered for purchase. No unregistered boat shall be placed on the Lake without a temporary permit. The property Owner, Renter or Lessee shall be the Operator of the Watercraft. (3 pts.)
3. All PWCs shall display two identically numbered decals. These decals may be obtained from the Association each year at registration (6 pts.). See Appendix A for placement of decals.
4. The lot and block numbers of the registered Owner shall be displayed on the Watercraft, before any Watercraft may be used on the Lake. The letters and numbers shall be contrast in color to the background upon which they are displayed, be a minimum of 3 inches in height, and be visible for at least 75 feet (3 pts.). See Appendix A for placement of lot and block numbers.
5. No watercraft, first registered after 1997, shall be registered to a lot unless the lot has constructed on it a structure that complies with all city codes, including restroom facilities.
 - a. Watercraft may be registered to a house under properly permitted construction, as long as the house has access to a professionally maintained portable toilet.
 - b. Any temporary authorization under Subsection 5(a) herein shall not exceed a period of one (1) year unless authorized by the Board of Directors
6. Service Permits: Contractors or Vendors who provide construction services, watercraft maintenance or repair, or similar services to Owners/Members on the lake may apply for a temporary permit for the sole purpose of supplying such services. The following additional rules apply to such temporary permits
 - a. The applicant shall complete the appropriate application and pay all required fees.
 - b. Each applicant shall annually pass an open book test on the Water Use Rules and Regulations of Lake Lotawana. Passing shall mean a minimum score of 80% accuracy.
 - c. Permits shall be issued on a per job basis, with a defined expiration date not to exceed one year.

d. When a permit is issued, the applicant shall receive a flag of designated color. The flag shall be prominently displayed on the Vendor's watercraft in a fashion visible from all directions, at all times the Vendor is operating on the lake.

e. All holders of temporary permits shall give notice to the Association office prior to each launching of the holder's watercraft on Lake Lotawana.

f. Use of the lake by the holder of any temporary service permit is subject to all rules and regulations, and city ordinances that may be relevant. Violation of any rule, regulation or City ordinance shall result in immediate revocation of the temporary permit, removal of the watercraft from the lake and the assessment of pointed to the Owner/Member receiving services.

7. Watercraft registered in 1988 and continuously registered thereafter that are not in compliance with the length or horsepower restrictions are eligible for registration to the owner of record as register in 1988. The following additional rules apply to such permits. Sale or transfer of pre1988 registered watercraft to another lake resident for use on Lake Lotawana is not permitted.

D. LAUNCHING OF WATERCRAFT:

A launching ramp is located on the easement in the lower parking lot of the Marina Grog and Galley. The Association Office and courtesy volunteers, whose names are listed in the *Lotawana News*, provide the lock's combination.

1. Each person using the launching ram is responsible for securing the lock on the gate after using this ramp. (3 pts.)
2. No Watercraft shall be launched into the Lake from the Parkway, unless specifically permitted by the Association. (3 pts.)

E. OPERATOR'S REQUIREMENTS:

The registered Owner of each Watercraft is liable for all violations incurred or caused by their Watercraft. It is the responsibility of the registered Owner to inform any non-resident Operator of the rules and regulations for Watercraft operation.

1. An Owner or Family member must be present when a Watercraft is operated on the Lake. A water skier is considered present. (6 pts.)

2. An Owner, Renter, or any member of their family residing with them, who is not the registered Owner of a Watercraft, but who is the Operator of said Watercraft, is liable for violations.

a. AGE REQUIREMENTS:

Persons under the age of 16 years shall not operate Watercraft with motors which exceed the horsepower set forth in the following schedule: (3 pts.)

<u>Attained Age</u>	<u>Maximum Horsepower</u>
under 9 years	not authorized to operate a Watercraft with motors
9	5 HP on not less than 14 ft. operate Watercraft with motors
10	10 HP
12	20 HP
14	40 HP
16	no limit

- b. No person under the age of 16 shall operate a PWC. (6 pts.) No person under the age of 17 shall operate a PWC, unless they have completed the Missouri Water Patrol Water Safety Class. (6 pts.)

F. EQUIPMENT:

1. PERSONAL FLOTATION DEVICE (PFD/LIFE PRESERVER):

Each Watercraft shall have a life preserver (vest, ski belt, buoyant cushion, or ring buoy) for each person aboard the Watercraft. Flotation devices shall be in serviceable condition and readily accessible. (3 pts.)

- a. Each person on a PWC shall wear a US Coast Guard approved PFD: Type I, II, III or V. (3 pts.)
- b. Any person on water skis or similar device (wake board, knee board, tube etc.), shall wear a PFD, designed to withstand the impact of hitting the water at high speed. A ski belt is not an acceptable flotation device for skiing. (3 pts.)
- c. Any person under the age of 13, as a passenger or Operator of a boat and not under direct adult supervision, shall wear a U.S. Coast Guard approved PFD, Type I, II, III or V (3 pts.).

2. FIRE EXTINGUISHER AND VENTILATION:

All Watercraft powered by any type of engine, electric gas or otherwise, shall be equipped with a fire extinguisher and an efficient natural or mechanical ventilation system (3 pts.).

3. MAXIMUM CAPACITIES:

All Watercraft manufactured after 1970 shall have a maximum capacity plate mounted in a position, so as to be readily visible by the Operator. This plate shall list the maximum operating limitations of the vessel in regard to the following:

- a. Number of persons allowed onboard;
- b. Total weight of gear allowed;
- c. Total combined weight of person and gear allowed;
- d. The maximum horsepower allowed for motors.
- e. Any failure to comply with the maximum capacity ratings of the Watercraft is prohibited. (6 pts.).

G. LIGHTING REGULATIONS:

1. Navigation lights shall be displayed one-half hour after sunset to sunrise and at any time the visibility is such that the Watercraft cannot be seen from a distance of 100 yards.
2. All Watercraft except sailboats shall have a combination of red (port) and green (starboard) lights on the bow of the boat and a 360 visible, white light on the stern of the boat. (3 pts.)
3. Sailboats shall only be required to illuminate the sail with a white light. (3 pts.)
4. Docking lights (headlights) on Watercraft shall only be displayed within 100 feet of shore when approaching a Dock or when approaching a stationary Watercraft. (3 pts.)
5. A Watercraft used for sport fishing, which is anchored or stopped within 100 feet of the shore, is not required to display navigation lights, unless another boat approaches within immediate vicinity of the Watercraft, at which time said fishing boat must activate lights in time to avoid a collision. (3 pts.)

a. SPOTLIGHTS AND SHORE LIGHTS:

Spotlights and Shore lights should not be used in any fashion that invades the privacy of others. Shore lights, boathouse lights and/or Dock lights shall not be mounted or directed in such a manner, as to present a hazard to boat navigation or in a manner that is objectionable to other residents (3 pts.).

- b. All underwater lighting is not permitted at Lake Lotawana. (3 pts.)

H. NAVIGATION RULES:

(Adapted from the Missouri Watercraft Manual, published by the Missouri State Water Patrol)

1. ALL POWERCRAFT SHALL PROCEED IN A COUNTER-CLOCKWISE MANNER. (3 pts.)

2. RIGHT OF WAY:

The slower, less maneuverable Watercraft has right-of-way over the faster, more maneuverable Watercraft. (3 pts.)

The right-of-way hierarchy is as follows:

- a. Watercraft not under command (anchored, moored, adrift).
- b. Canoes, rowboats, paddle boats, kayaks.
- c. Sail boats.
- d. Vessels under tow
- e. All other power craft

1. Note: All power craft shall yield the right-of-way to a vessel returning to retrieve a downed skier in the water.

3. MEETING HEAD-ON:

When meeting head-on neither Watercraft has the right-of-way and shall both steer to the right, passing to the port side of each Watercraft, so as not to pass closer than 50 feet. (3 pts.)

4. OVERTAKING:

When passing another Watercraft from behind (astern), the overtaking Watercraft shall keep clear of the Watercraft being passed. The passing Watercraft may pass to either side of the overtaken Watercraft, as long as it stays at least 50 feet from the other boat. (3 pts.)

5. WHEN CROSSING THE PATH OF ANOTHER WATERCRAFT:

The Watercraft on the right (starboard) has the right-of-way. The crossing Watercraft shall steer clear and pass behind (astern) of the right-of-way Watercraft. The crossing Watercraft shall do everything possible (stop, slow, even reverse direction), to avoid the right-of-way Watercraft. A Watercraft entering the main body from a Dock or Cove shall yield to watercraft in the main channel until it is safely out in the channel, at which point, all regular navigation rules apply. (3 pts.)

6. DEFENSIVE BOATING:

It is every Operator's duty, to take whatever action necessary to avoid a collision. Do not assume you have the right-of-way in any given situation.

Keeping a proper operating distance can give you enough time to recognize a hazardous situation, and the room to avoid it. Never make a course change without making a 360° survey of the traffic around your Watercraft. Knowing the location of other Watercraft will give you an advantage in avoiding an accident. All power craft shall operate in a counter-clockwise traffic pattern.

I. NEGLIGENCE OPERATION:

No person shall operate any Watercraft in a reckless or negligent manner, so as to endanger the life or property of any person. Negligence includes, but not limited to, endangering other Watercraft, swimmers, skiers, downed skiers, fishermen, sailors, Docks or buoys. (6 pts.)

1. No Watercraft shall cut in front of or across the path of another Watercraft on a fixed course, unless maintaining a distance of 150 feet. (6 pts.)
2. No Watercraft shall follow closer than 300 feet behind a power craft that is pulling a person on water skis or other similar device. (6 pts.)

a. PROHIBITED ACTIVITIES:

1. Unsafe conduct which might cause the operator to lose control or cause a person to fall out of the watercraft. (3 pts.)
2. Sitting on the gunwales (sides of boat) or on the decking over the bow or stern while the Watercraft is being operated in excess of Slow No-Wake speed. (3 pts.)
3. Power craft races. (3 pts.)
4. Operating a Watercraft through or near a sailing competition race, while not a part of that competition, in such a manner which endangers the life, limb or property of any Watercraft taking part in said race. (3 pts.)
5. Jumping into the water from a moving Watercraft. (3 pts.)
6. Driving a pontoon boat with passengers occupying the upper deck. (3 pts.)
7. An operator may plow the water in the middle of the Lake so long as the wake does not cause dock or shoreline damage. "Plowing is defined as operating a watercraft at a speed and in a fashion creating a wake while not pulling a skier or another boat. (3 pts.) (added 2/07; points adopted 10/9/07)
8. Operators and passengers in watercraft shall not make excessively loud noise after midnight. Noise is excessive if it disturbs the peace of others, including screaming, shouting, loud music. (6 points)

9. No person shall engage in belligerent or abusive behavior, or use profanity or otherwise engage in behavior likely to disturb the peace of others. (6 pts.)

J. BOATING WHILE INTOXICATED (BWI):

1. No person shall operate any Watercraft while under the influence of alcohol or drugs as defined by the BWI levels established by the State of Missouri. (6 pts.)
2. Any person who operates a Watercraft while exceeding the BWI levels established by the State of Missouri, and who causes damage to person or property, shall receive 15 points and a one year suspension of Lake privileges.
3. All Lake privileges and permits of any Watercraft Operator who refuses to take a breathalyzer test or blood alcohol study, when requested by a police officer or any employee of the Association shall be revoked for a period of 1 year as of the date of the refusal.

K. SPEED LIMITS:

1. DAY TIME SPEED LIMIT:

No person shall operate a Watercraft on the main body of the Lake at a speed in excess of 40 miles per hour. (6 pts.)

2. NIGHT TIME SPEED LIMIT:

Maximum speed limit on the main body of the Lake, between the hours of one-half hour after sunset to sunrise, is 10 miles per hour or less with minimal wake. (6 pts.)

3. SLOW NO-WAKE LIMITS:

Slow No-Wake speed is defined as the slowest speed at which a Watercraft will move through the water, while being able to maintain course and create minimal wake.

a. SHORELINES:

No person shall operate a boat within 100 feet of the shoreline in excess of Slow No-Wake speed, or in a manner that endangers persons, property, or causes excessive wake or wash. (6 pts.)

b. COVES:

No person shall operate a Watercraft within any Cove in excess of Slow No-Wake speed, or in a manner that endangers persons, property, or cause excessive wake or wash. (6 pts.)

L. OFFICIAL WATER TRAFFIC CONTROL DEVICES AND SHORELINE BUOYS:

1. OFFICIAL WATER TRAFFIC CONTROL DEVICES:

Official Water Traffic Control Devices are markers placed on the Lake, specifically at the entrances to Coves to indicate areas where Watercrafts are to be operated at a slow no-wake speed. Watercraft Operators shall observe all water traffic control devices. (3 pts.)

- a. No person shall damage or relocate a water traffic control device unless directed to do so by an appropriate agent. (6 pts.)
- b. No person shall moor a Watercraft, or any other object, to a water traffic control device. (3 pts.)

2. SHORELINE BUOY DESIGN:

Shoreline Buoys shall extend above the water a minimum of 15 inches and be of a highly visible color. Buoys shall be securely anchored. Buoys of metal construction, such as Freon bottles or beer kegs, are prohibited. (3 pts.)

3. SHORELINE BUOY PLACEMENT:

No shoreline buoy shall be placed more than 100 feet from shore. (3 pts.)

- a. No person shall damage or remove another property Owner's shoreline buoys. (6 pts.)
- b. No person shall moor a Watercraft, or any other object, to another property Owner's buoy, without permission from the buoy's Owner. (3 pts.)

4. SHORELINE LIMITATIONS:

No person shall operate a Watercraft or PWC within 100 feet of the shoreline, except for the express purpose of approaching or leaving the shoreline, and only then, after ascertaining that there are no swimmers in the immediate area. Any person fishing within the 100 feet limit may cruise at trolling speed, keeping a vigilant lookout for swimmers and other persons. Sailboats may enter within the 100 feet limit during sanctioned races, provided they do not place any person or property in danger.(6 pts.)

M. PERSONAL WATER CRAFT (PWC):

1. All PWC's shall be equipped with the following equipment:

- a. **Kill Switch:**

All PWCs shall be equipped with a lanyard-type kill switch; the lanyard shall be attached to the Operator at all times of operation. (6pts.)

b. Maximum Horsepower (HP):

No PWC shall be operated on the Lake that does not comply with the following horsepower limitations:

1. 2 Stroke/1 Rider

- a. A 2 stroke PWC certified for one (1) rider shall not have an engine larger than 700 cc.
- b. A 2 stroke PWC certified for one (1) rider shall not exceed 75 HP.

2. 2 Stroke/2 Riders

- a. A 2 stroke PWC certified for two (2) riders shall not have an engine larger than 750 cc.
- b. A 2 stroke PWC certified for two (2) riders shall not exceed 90 HP.

3. 2 Stroke/3 Riders

- a. A 2 stroke PWC certified for three (3) riders shall not have an engine larger than 800 cc.
- b. A 2 stroke PWC certified for three (3) riders shall not exceed 110HP.

4. 4 Stroke/3 Riders

- a. A 4 stroke PWC certified for three (3) riders shall not have an engine larger than 1500 cc.
- b. A 4 stroke PWC certified for three (3) riders shall not exceed 130HP.

5. PWCs certified for more than three (3) riders are prohibited.

2. OPERATION REGULATIONS:

- a. PWC's shall comply with all regulations relating to Watercraft.
- b. A PWC driver is responsible to watch for other traffic and drive in a safe manner.
- c. No person under the age of 16 shall operate a PWC. (6 pts.)
- d. No person between the ages of 16 and 17 shall operate a PWC, unless they have completed the Missouri Water Patrol Water Safety Class. (6 pts.)

- e. No person shall carry passengers on a PWC in excess of the manufacturer's specified limits. (3 pts.)
- f. Every person on a PWC shall wear a U.S. Coast Guard approved personal flotation device (PFD): Type I, II, III, or V. (3 pts.)
- g. No PWC Operator shall allow another to ski or be towed behind a PWC. (3 pts.)
- h. No PWC shall weave through traffic, at other than idle speed. (3 pts.)
- i. No PWC shall jump through the wake of another Watercraft. (3 pts.)
- j. No PWC shall operate at a speed in excess of Slow No-Wake within 50 feet of any Watercraft. (3 pts.)
- k. No PWC shall operate in a fashion so as to become a nuisance to residents. (3 pts.)
- l. On the Holidays of Memorial Day, Independence Day & Labor Day, see Appendix F for holiday time restrictions.
- m. All PWCs shall operate in a counter-clockwise direction around the lake at all times. (3pts.)

N. WATER SKIING:

1. GENERAL:

- a. The term "water skier," as used in the following regulations, includes all persons being pulled by a Watercraft on water skis or on similar devices, such as a wake board, aquaplane, tire tube, inner tube, zip sled, disk, surfboard, air chair, or any other similar device.
- b. Any Watercraft Operator towing a water skier is responsible to watch for other traffic and proceed only in a safe manner. The Watercraft Operator is primarily responsible for the skier(s) he tows.
- c. The Water Patrol may curtail skiing during periods of heavy Watercraft traffic.

2. EQUIPMENT REQUIREMENTS:

All Watercraft towing a skier shall have the following

a. APPROVED SKI FLAG:

- 1. A red flag shall be affixed to the bow of the Watercraft or at the highest point when ski tower or racks are installed, forward of the windshield and perpendicular to the deck *at all times* a Watercraft is pulling a skier. This flag shall be a minimum of 10 inches square, and shall be displayed at a height so that the bottom of the flag is at

least 24 inches above the deck. The flag shall be visible for 360 degrees.

2. Flags on pontoon boats shall be mounted at the highest point. When 360° visibility cannot be obtained, two flags shall be flown, one fore and one aft.

3. Hand holding of a ski flag is not permitted.

4. A Watercraft is deemed to be pulling a skier from the time the skis, rope, and/or skier enter the water until the time the skier, rope, and skis come out of the water. (3 pts.)

b. PERSONAL FLOTATION DEVICE (PFD):

A person on water skis or similar device shall wear a PFD, which is designed to withstand the impact of hitting the water at high speeds. A ski belt is not an acceptable flotation device for skiing. (3 pts.)

c. TOW ROPE:

No person on water skis shall use a tow rope, which is less than 25 feet in length or more than 80 feet in length. A training boom affixed to a power craft is an acceptable towing device, provided that a distance of 8 feet from the skier and the side of the boat is maintained, as long as the device assures the skier will not come in contact with the power craft while skiing or in the event of a fall. (3 pts.)

3. TIME AND VISIBILITY REGULATIONS:

a. DAILY HOURS:

No person shall operate a Watercraft and pull or attempt to pull a water skier, prior to sunrise, 1/2 hour after sunset, nor at any time visibility is such that the water skier may not be seen from a distance of 100 yards. Prior to May 15th and After September 15th the stop time shall be at Sunset. (6 pts.)

b. HOLIDAYS:

On the days making up Memorial Day weekend, Labor Day weekend and Independence Day weekend, no vessel shall pull more than one skier. (3 pts.) Memorial Day and Labor Day weekends include Saturday, Sunday and Monday of the holiday weekend. The Lotawana Association shall determine and post the days encompassing Independence Day weekend each year. For additional holiday restrictions see Appendix F.

- c. Skiing may also be restricted or curtailed during any special event, as determined by the Executive Committee of the Association (3 pts.).

4. OPERATION REGULATIONS:

a. OBSERVER:

No person shall operate a Watercraft while pulling a water skier, unless there is in the Watercraft, in addition to the Operator, an observer who is in a position to communicate readily with the Operator, and who is observing the water skier in a competent manner. The minimum age for an observer is 5 years. (3 pts.)

b. MAXIMUM NUMBER OF SKIERS:

No person shall operate a Watercraft while pulling more than 2 water skiers, either separately or together, on the same device at the same time. (3 pts.)

c. NO SKIING IN COVE:

No person shall operate a Watercraft while pulling or attempting to pull a water skier within a Cove, designated as such by an official water traffic control device. (6 pts.)

d. THE FOLLOWING ACTIONS ARE PROHIBITED WHILE WATER SKIING:

1. Cutting in front of or across the path of a Watercraft on a fixed course, unless maintaining a distance of 150 feet. (6 pts.)
2. Swinging out so as to have any objects, such as Watercraft, buoys, or swimmers, come between the skier and the towboat. (6 pts.)
3. Skiing within 100 feet of any shoreline, or inside of any Cove marker, with the following exception: after a water skier has let go of the rope, he or she may ski into the 100 foot safety area to within 75 feet from the shore under his or her own power. (6 pts.)
4. Skiing while under the influence of alcohol or drugs. (6 pts.)
5. Taking off from any Dock, pier, or other structure extending from the shoreline. (3 pts.)

6. Skiing within 50 feet of another Watercraft. (3 pts.)
 7. Skiing within 50 feet of another skier or fallen skier, unless both skiers are being pulled by the same Watercraft. (3 pts.)
 8. Carrying another person, animal, or object while skiing. (3 pts.)
- e. **JUMP RULES: SEE APPENDIX B (LAKE LOTAWANA SKI CLUB JUMP RULES)**
- f. **WAKE SURFING:** Wake surfing shall only be performed behind a direct drive inboard type Watercraft, in which the propeller is located under the keel of the boat.
1. In addition to the Watercraft Operator, an observer must be present on a Watercraft towing a wake surfer.
 2. No water bladders or other Watercraft weight enhancement devices shall be used during wake surfing or at any other time. This rule applies to all boats operating on the lake regardless whether wake surfing or not. (9 pts)
 3. No person shall sit on the Watercraft's gunwale or on the transom during wake surfing.
 4. A wake surfer may use a ski rope less than 25 feet long.
 5. Wake surfers shall comply with the water skiing life preserver requirements.
 6. Wake surfing is allowed Monday thru Friday. Wake surfing is not allowed on weekends, Memorial Day, Independence Day or Labor Day.
 7. Wake surfing shall be limited to areas near the dam and at the south end of the Lake near Goat Hill. Wake surfing on the south end by Goat Hill is only permitted in the middle of the Lake. All wake surfers shall maintain a minimum distance between the power craft and swim buoys or Cove markers of at least 100 yards.
 8. Violations of wake surfing requirements shall be a six point offense. (6 pts.)
- g. A fallen skier should, if at all possible, immediately raise one ski perpendicular to the water so that at least 24 inches or more of the ski is visible out of the water.

O. SWIMMING:

A swimmer, or any person using a raft or any flotation device, shall stay within 75 feet of the shoreline. Swimmers and persons using flotation devices are permitted to swim from a Watercraft inside of a Cove, as designated by an official Water Traffic Control Device, provided that they stay within 75 feet of the Watercraft. (6 pts.)

P. FISHING:

1. SIZE LIMITS:

All Channel Catfish less than 14 inches in total length shall be returned to the water, unharmed, immediately after being taken from the Lake. Total length is measured from the tip of the snout to the end of the tail, with the fish laid flat on the rule, with the mouth closed and tail lobes pressed together. (3 pts.)

a. All Black Bass less than 12 inches and greater than 15 inches may be kept. Bass 12 to 15 inches in length, measured from the tip of the snout to the end of the tail, shall be returned to the water, unharmed, immediately after being taken from the Lake. (3 pts.)

b. Carp may be taken by hook and line, gig, longbow, crossbow, pitchforks, wire hoops or any other device allowed by the Missouri Wildlife Code, not herein expressly forbidden. (3 pts.)

c. Special purpose fish (walleye and striped bass) shall be returned to the Lake unharmed. (3 pts.)

2. CRAPPIE BEDS:

Any brush or Christmas tree used for the establishment of crappie beds shall be sunk in water not less than 10 feet deep and adequately moored so as not to present any obstacle to boat traffic or pose any danger to swimmers. (3 pts.)

3. BAIT FISH PROHIBITED:

No carp, sucker, or other rough fish minnows shall be used as bait. Leftover minnows shall not be thrown into the Lake. (3 pts.)

4. PROHIBITED FISHING METHODS:

No person shall use any electrical device, explosive, poison, or chemical to kill, attempt to kill, capture or stupefy fish. (3 pts.)

5. No person shall use trammel net, hoop net, gill net, seine nets, or fish traps to take fish. No fishing with limb lines, trot lines, or jug lines. (3 pts.)

6. No fishing allowed from dam, spillway, bridge, or dam site boat Docks. (3 pts.)
7. No person shall feed any Canada Geese (3 pts.)

Q. MISCELLANEOUS:

1. LITTER:

No person shall deposit in the Lake or on the Parkway any vegetation including leaves, grass tree limbs, trash, fish offal, or other offensive substances. (3 pts.)

2. CHEMICALS:

No person shall use any chemical in the Lake, or reasonably likely to enter the Lake for the control of weeds or algae growth, except with written permission from the Association. (15 pts.)

3. No person shall bath in any fashion using any chemical while swimming in the Lake. (3 pts.)

4. AIRCRAFT PROHIBITED:

No person shall land or takeoff any aircraft from the surface of the Lake or adjacent Parkway or easement. (3 pts.)

5. FIREWORKS:

Fireworks and discharge of fireworks within the Subdivision is prohibited at all times. (6 pts.)

6. SPECIAL PERMITS:

The Executive Committee of the Lake Lotawana Association may issue special permits, which grant certain privileges to individuals or organizations to engage in activities, which would be contrary to these water use regulations. Failure to obtain a special permit 3 pts.

7. WATER SKI SHOWS AND EXHIBITIONS:

A permit may allow for the number of water skiers to exceed the lawful limit, for stunting and for other activities associated with water ski shows or similar water activities. Each section of the rules and regulations to be waived must be identified in such a permit. Any person operating a Watercraft with a

special permit shall display an exhibition flag of the same dimensions as the regulation ski flag, consisting of two halves—red over white.

8. SCUBA DIVING:

Scuba Diving in Lake Lotawana is prohibited, unless a special permit is obtained from the Association. This permit is reserved for underwater salvage operations and special circumstances.

9. TRAPPING:

- a. Nuisance rodents (i.e., muskrat, mink, and beaver) may be trapped within Lake Lotawana waters provided the trapper obtains a special permit. Only a Lake resident, property Owner or a person contracted by a Lake resident or property Owner are eligible for trapping permits.
- b. Trapping procedures and equipment shall comply with Missouri Conservation Department Regulations.

10. HOLIDAY SAILBOAT RESTRICTIONS:

See Appendix F for holiday sailboat racing time restrictions

11. MOVEMENT OF WATERCRAFT

No person shall move another person's Watercraft without permission from said Watercraft's Owner. (3 pts.)

SECTION IV: USE OF OTHER COMMON AREAS

A. General Rules Applicable to All Permits

1. All permits issued by the Association for use of its property are licenses and revocable at will by the Association. As partial consideration, any applicant or holder of a license for any use of Association property agrees that permittee's expenditure of funds does not convert the license issued by the Association for such use to some greater interest in the Association property. Irrespective of such expenditures, all permittees agree, as partial consideration for the issuance of any permit, that their licenses shall remain fully revocable by Association.
2. Prohibited acts:
 - a. No person or entity shall commence construction or improvement of structures on the Common Areas without the written permission of the Lake Lotawana Association.
 - b. No person shall hold, and/or place any structure on the Common Areas without first obtaining a permit from the Lake Lotawana Association. (6 pts.)
 - c. No person shall willfully give false information on an application for a permit to construct, modify or place a structure on Common Area. (3 pts.)
3. The Owner of record shall obtain a revocable permit from the Association and a Construction Permit from the City of Lake Lotawana and before constructing, modifying, and/or placing any structure on the Common Areas. The Owner shall deliver a copy of the City permit to the Association. The improvements shall be constructed, modified, placed, and/or maintained in accordance to the requirements of the permits.
4. Only an Owner with legal title in his/her name may apply for and retain a permit to construct or maintain a structure on Common Area. Property held corporately, in trust, or jointly in any fashion must designate an individual as the responsible party for the property for all purposes relating to permits. A permit shall automatically be revoked by the Association without further process or notice if the permit holder or property represented by the holder fails to pay all current assessments due on *any* properties owned
5. A silt fence or other approved erosion control device shall be used for any construction or excavation that may result in runoff.

6. No Owner, designated representative or family member under any suspension by the Association may apply for a construction or use permit of any type.
7. Scaled dimensional drawings, including site plan, structure details and material lists are required with all permit applications.
8. Applications for construction permits must be approved by the Lake Improvement Board, but their staff may approve minor construction and exact replacements of existing structures in the Common Areas.
9. Applications must be submitted for hearing by the Lake Improvement Board by the first of the month. Lake Improvement Board meetings are scheduled on the fourth Thursday of each month.
10. As consideration for permits granted, the Applicant-Owner agrees to assume all responsibility for personal injury or property damage caused or contributed to by the construction. Applicants will indemnify and save harmless Lake Lotawana Association, their affiliates, officers, directors, and shareholders, from any loss, including attorney's fees and all other claims of damage, of whatsoever kind or character, caused or claimed to have been caused by the permitted construction.
11. Any construction violation or variance from the Extension of Restrictions shall result in assessment of Violation Points. (3 pts.) Non-compliance within 30 days shall result in an assessment of one point per day until the violation is corrected.
12. Electrical Work On Common Areas, Seawalls, And Docks:
 - a. Electrical work on such areas requires a construction permit. All work shall conform to the standards set by both the LLA and any applicable City of Lake Lotawana building codes. (6 pts.)
 - b. All electrical circuits on Common Areas shall be protected by ground-fault interrupters. (6 pts.)
 - c. All lighting on the Common Areas shall be subject to the approval of the Lake Improvement Board. (3 pts.)
13. Any permit may be revoked by The Board of Directors of the Lake Lotawana Association. Permits are revocable under the terms of the Lake Lotawana Association Bylaws and Deed of Restrictions. Notification of permit revocation shall be made to the current Owner/member, as shown on Association records.
14. Any Owner may apply for an exception to the rules herein by appealing to the Lake Improvement Board. Any exception requires proof of extraordinary

circumstances making compliance with a rule impractical. Decisions of the Lake Improvement Board are appealable as herein provided.

15. Any construction or excavation that may result in runoff shall be fenced with a silt fence or other approved erosion control device. (6 pts) Non-compliance will result in assessment of one point per day until the violation is corrected.
16. All permits must be prominently displayed and readable.
17. Any violation of the Deed of Restriction, City Building Codes, Lake Building Regulations or any construction violating the two (2) foot strip surrounding Lake Lotawana without appropriate permit, may, after notice and an opportunity to be heard, result in a \$100 fine per month while the violation continues and assessment of costs to cover the Association legal fees

B. Rules relating to Dock construction and usage:

1. Dock Permit Requirements:

- a. All placements of Docking structures of any type on the Lake, including an expansion, realignment or replacement of an existing Docking structure, must be approved by the Lake Lotawana Association. The Association may exercise discretion to deny or modify a request based on the need to balance all lot Owners' utilization of the Lake.
- b. Placement of a Docking structure of any type on the Lake, including an expansion, realignment or replacement of an existing Docking structure is a privilege granted to Owners who are current on assessments and who are abiding by all the rules and regulations of the Lake Lotawana Association.
- c. No Dock permit will be issued to any property without inhabitable living quarters connected to an approved sewer system.
- d. The placement of any new Docking structure for non-waterfront property must be within one half the distance to a platted Pathway in either direction from the nearest platted Pathway.
- e. All Docking structures must have access from the Parkway.
- f. Boathouses, defined as an enclosed Boat Dock that includes a roof and walls, will not be permitted. Any Boathouse permitted prior to 1991 may be kept on the Lake, but may not be moved or modified in any way.

- g.** No dock shall have any cover or tarp suspended or draped so as affect the view through the dock or to create the effect of a covered boathouse. (3 pts)
- h.** Only one (1) Docking structure permit shall be issued to each lot except where permitted by the Lake Improvement Board.
- i.** All Docking structures shall be a minimum distance of 15 feet from adjacent Docking structures.
- j.** A pontoon Boat shall not be used as a Boat Dock.
- k.** A license plate issued to a specific Dock shall not be removed and placed on any other Dock, unless specifically authorized by the Association.
- l.** Existing Docking structures being replaced shall be disposed of by demolition by the Owner or by contract with the Association.
- m.** Relocation and/or modifying an existing Dock other than a minor repair require a new permit. No person shall repair a Docking structure requiring material replacement of 50% or more as determined by the Lake Improvement Board, without first obtaining a permit. (3 pts.)
- n.** No Dock construction/placement permit may be transferred or assigned in whole or in part without the written consent of the Association.
- o.** The Owner of each Docking structure or Boat lift EXCEPT Hydro Hoists type lifts installed in Boat wells of existing Docks on the Lake must register that structure with the City of Lake Lotawana and the Lake Lotawana Association. (3 pts.)
- p.** Permits for Dock space may be shared by more than one lot Owner. Any Docks-space licensed to more than one lot shall have in place a written agreement detailing the parties' agreement with respect to Ownership, repair and use of the doc itself. Should the parties be unable to agree on the language of a written agreement, the standard agreement of the Association, found in Exhibit E shall be deemed to be agreed upon by the Dock Owners.
- q.** Attachments to Seawalls: Attachments to seawalls, other than by Owner, shall be made only with the specific written permission of the Owner of the seawall. Where such permission is withheld, attachments for approved Docks and structures shall be made from the Lake bottom or on the Parkway as approved by the Lake Improvement Board. (3 pts.)

- r. All Structures excluding docks/lifts, including trampolines, islands and any inflatable devices between 6 feet and 12 feet in diameter must be permitted before it may be used on the lake. Such devices may not be used outside the “no wake zones” and must be stored on the owner’s/member’s dock or other appropriate location off the lake when not in use

2. Dock Structural Requirements and Limitations:

- a. All Docking structures must be constructed in accordance with the requirements set forth in the permit. (3 pts.)
- b. Any construction, modification, location, relocation, or repair of a structure shall be completed within 12 months from the date a permit is issued. Permits may be renewed upon appropriate application and approval by the Association. (3 pts)
- c. All Docking structures must be placed or located according to the requirements set forth in the permit. (3 pts.)
- d. Each Docking structure shall be moored properly so as not to present a hazard on the water or on the Parkway. (6 pts.)
- e. No Docking structure shall have living facilities, dressing rooms, and toilet or sink facilities. (3 pts.)
- f. The maximum dimensions of an individual Docking structure shall be 36 feet wide as measured along the shoreline and 28 feet long measured perpendicularly from the shoreline. (3 pts.)
- g. The minimum dimensions for the deck of a Docking structure shall be 8 feet wide measured along the shoreline and 8 feet long measured perpendicularly from the shoreline. (3 pts.)
- h. The maximum width of the roof of an open type Docking structure shall not exceed two (2) feet on either side the width of the deck of the Dock. (3 pts.)
- i. The peak of the roof of the Docking structure shall not exceed 12 feet in height above the deck. The minimum heights of the roof shall not be less than 6 feet above the deck. (3 pts.)
- j. The maximum height of the deck of a Docking structure shall be 3 feet above the water level. (3 pts.)
- k. Barrels and Bead board Styrofoam consisting of a compressed “white bead” consistency shall not be used for Dock flotation at any time.

- l.** Gangway, ramp or catwalk width shall not exceed the width of the Docking structure to which it is attached nor be more than 12 feet long, and must approach and attach to the shore side of the structure. (3 pts.)
- m.** No Dock box may be larger than 3 feet high by 6 feet wide by 3 feet deep.
- n.** Dock Floatation: All new and permitted remodeled Docks shall use floatation tubs made of a polyethylene shell that encapsulates polystyrene foam. Barrels of any type and expanded polystyrene logs or blocks “white bead foam” shall not be used as Dock floatation in new or replacement construction. Blue or orange extruded polystyrene “Styrofoam™” logs shall not be used as Dock floatation in new construction. For maintenance purposes, blue or orange Styrofoam™ logs may be used to replace up to 20% of a Dock’s existing foam floatation within a one year period. Docks requiring more than 20% replacement of the blue or orange Styrofoam™ logs shall convert to 100% encapsulated foam tubs.
- o.** The construction, modification, location, relocation, or repair of a structure shall be completed within 90 days from the date of issuance of permit unless extended by the City of Lake Lotawana and the Association. (3 pts.)
- p.** All Docking structures shall be identified by Lot and Block numbers in letters and numerals at least 3 inches in height in a contrasting color, and attached to a vertical surface of the Dock clearly visible from the Lakeside. (3 pts.)
- q.** All Dock structures shall be identified with the proper license plate, as issued by the Association, attached to a vertical surface of the structure visible from the Lakeside. (3 pts.)
- r.** All floating structures shall maintain a reasonable level condition of the deck and any wood members of the structure shall be a minimum of 2 inches above the water. (3 pts.)
- s.** Privilege to utilize a Docking space shall exist for a maximum of one year from the date the Association confirms a Docking structure is not occupying its authorized space. At the time of confirmation, the Association shall notify permit holders by certified mail.

3. Removal of Docks:

- a. Unsafe Docks and Docks in Disrepair: No Dock may be kept in an unsafe, neglected, dilapidated or other condition that is not in compliance with the Rules and Regulations of Lake Lotawana Association.
- b. The permit holder for any Dock location is responsible for the condition of the Dock moored thereon.
- c. Any Dock determined by the Association or the City of Lake Lotawana to be unsafe, noncompliant, or in disrepair shall be subject to removal. "Unsafe Docks" and "Docks in Disrepair" are those which "threaten the health, safety and well-being of a resident" or are in a hazardous or dangerous condition, not meeting minimum construction and safety standards.
- d. Removal Based on Condition.

Any Dock determined to be unsafe or in disrepair as defined in the preceding paragraph may be removed from the Lake as follows:

1. The permit holder for the Dock shall be notified by regular and certified mail at their last known address with the Association of the deficient condition. The holder shall have 30 days to repair or replace the structure, unless extended by the Association.
2. If the holder fails to repair or remove the structure in the allotted time, or fails to appeal the notice as described herein, the Association may, in its sole discretion and without further notice remove the Dock from the permitted location.
3. The Dock space shall, at the expiration of 1 year or any extension granted, whichever is later, be declared open for purposes of new permitting.
4. The Association will hold the removed Dock structure for a period of 60 days, after which it will be deemed, abandoned and disposed of appropriately. All costs associated with removal shall be assessed against the permit holder, and if more than one, shall be assessed pro rata.
5. Any person may appeal the notice to repair or remove to the Lake Improvement Board. Appeal must be filed within 10 days of mailing of the notice of repair or removal. During the pendency of the appeal, all actions and time periods shall be stayed unless the Association determines the Dock condition represents an immediate and present danger to others.

- e. **Removal Based on Delinquency**
 - 1. The permit of any Dock permit holder whose assessments are two years in delinquency as of February 28 of any year shall automatically be revoked on March 1 and the vacancy declared open for purposes of new permitting.
 - 2. If a permit has been revoked for delinquency, the Dock Owner shall be given a 10-day notice by certified and regular mail of the revocation. Thereafter, the Owner shall have 30 days to remove the Dock or to appeal the decision to the Lake Improvement Board. Upon the permit tee's failure to do either, the removal notice shall be final.
- f. The Association may remove any unclaimed Dock, or Dock not associated with a block and lot without any notice.

4. Mooring Privileges and Mooring Space:

- a. An Owner/member of the Lake Lotawana Association has the privilege of mooring a Watercraft to his or her Dock, subject to the rules and regulations of the Lake Lotawana Association. No Owner/member shall moor a Watercraft or any other devices such as but not limited to water trampolines in such a manner as to deny access to the mooring of any Owner/member's Watercraft, to either side, front or back of a structure (Dock/life) for which it was designed.
- b. When there is a mooring space between two Docks that can accommodate two Watercraft and the space is reduced to hold only one Watercraft, the property Owner with the least culpability for the decreased space shall have priority to the remaining space.
- c. An Owner/member who does not have adequate Docking or mooring facilities, as determined by the Lake Lotawana Association, shall register the Watercraft as daily launch and removal. All other Watercraft permits shall designate the assigned mooring space for the Watercraft. All Watercraft must be moored at the space assigned in the Watercraft permit.
- d. Maximum mooring distance from any Dock shall be a foot or less, using any Mooring whip or bumpers.
- e. The allocation of mooring space between two adjacent Docks shall be determined by the two adjacent Dock Owners. No Owner/member shall move, or cause to be moved by others, the Watercraft of another with the intent to change prior usage without the consent of all affected parties.

- f. If the property Owners cannot reach an agreement concerning the allocation of mooring space, any party may submit a written request to the Water Use Enforcement Board to determine mooring priority.
- g. The Water Use Enforcement Board shall conduct an investigation of the dispute as expeditiously as possible. All parties shall have the opportunity to appear before the Water Use Enforcement Board to present evidence and argument. The Water Use Enforcement Board shall hear the evidence and place priority in achieving a solution which is agreeable to both parties. The Board shall consider the size and type of Watercraft involved, the position of other Watercraft parking in the area, the prior usage of the area in dispute, and all other relevant factors in making its decision. The decision of the Water Use Enforcement Board shall be delivered to the parties in writing.
- h. The decision of the Water Use Enforcement Board may be appealed to the full Board of Director of the Association, which will hear the matter de novo. During the appeal process, the parties shall comply with the decision of the Water Use Enforcement Board. Non-compliance during the appeal with the Water Use Enforcement Board's decision shall result in the issuance of one (1) point per day and may be taken into consideration by the Board of Directors to resolve the matter. All decisions of the Board of Directors shall be final.
- i. A property Owner who purchases property with mooring space assigned to the property shall have, upon application and approval, the same usage and mooring privileges for Watercraft as the previous Owner.
- j. Absence of Watercraft from a licensed mooring location for 12 consecutive months shall constitute abandonment of the location. Absence of Watercraft for seasonal storage or maintenance will not be grounds for reallocation of the mooring space.

C. USE OF RIGHT OF WAY:

As used herein "Roads" shall mean the right of way as defined by the plats of Lake Lotawana recorded in the Recorder of Deeds Office for Jackson County at Independence, Missouri.

- 1. No person shall construct anything on the Roads without first obtaining a permit from the Association. (3 pts.)
- 2. No person shall operate a vehicle with a weight of more than 12000 pounds per axle on the Roads without a load permit from the Association office. This restriction shall not apply to commercial trash vehicles. (3 pts.)

3. No person shall excavate or cut the road surface, shoulder area, or road ditches, nor shall any person bore under the road or connect a private way or other road to the Road first obtaining a permit from the Association. (3 pts.)
4. No person shall encroach on the Roads including driveways and parking ramps without a permit. (3 pts.)
5. No person shall dispose of debris, such as leaves, vegetation and hazardous liquids on the Roads, Pathways or any other Common Areas. (3 pts.)
6. No person shall discharge any substance, including water onto Road in a fashion that damages Road surfaces. (3 pts.) The Lake Lotawana Association may at its election and without notice, remove and repair the discharge and bill the property Owner.
7. No person shall repeatedly park any vehicle across the white line marking the edge of the Road. (3 pts.) Non-compliance will result in 1 additional point per day.
8. All newly constructed driveways and parking pads shall be hard surface or open hard surface.
9. No person shall operate any pocket bike, less than 50 cc, mini bike or go-cart on Association Roads.
10. No person shall operate any motorized vehicle unless licensed by the State of Missouri to drive on public right of ways. Acceptable licenses shall include any license recognized by the State of Missouri.(3 pts.)

D. USE OF PARKWAY AND PATHWAYS:

1. No launching ramps shall be constructed on the Parkway without a permit from the Association. (3 pts.)
2. New structures extending above grade shall not be constructed on the Parkway. This includes storage building, decks, Covered patios, gazebos, and all similar structures. (3 pts.)
3. The construction or placement of any structure on the Parkway or Pathways, such as steps, walkways, railings, pipes, wires and Dock guy lines, which restrict access or present a dangerous condition, are prohibited. (6 pts.)
4. All construction and repair of seawalls or retaining walls shall be approved by the Lake Improvement Board. (6 pts.)

5. No person shall perform any construction activity over or on any part of the sewer lines of the City of Lake Lotawana without first obtaining a permit from the City of Lake Lotawana, in addition to the permits required herein, and delivering the same to the Association. (3 pts.)
6. No engine or motor-powered passenger car, truck or recreational vehicle shall be driven across or on the Parkways and Pathways without a permit from the Association. Equipment used for grass mowing and lawn maintenance shall be allowed. Vehicles considered for approved access on the Parkways and Pathways shall include:
 - a. Construction vehicles and equipment used for permitted construction on the Parkways and Pathways. The vehicles used for construction purposes on the Parkways and Pathways shall be listed on the Application for Construction approved by the Association.
 - b. Golf carts used to transport passengers and Boating equipment directly to and from Boat Docks. Golf cart Owners shall annually apply for a Parkway Vehicle Permit for the purpose of driving on Parkways and Pathways. A Parkway Vehicle Permit decal, Block and Lot Numbers shall be displayed on the golf cart.
 - c. Parkway Vehicle Permit applicants shall provide proof of insurance; agree with the conditions listed on the Association's Parkway Vehicle Permit and pay applicable fees (Violation: 3 points).
7. Illumination and Lighting: All lighting on the Common Areas shall be subject to the approval of the Lake Improvement Board. No person shall install any lighting or illumination without first obtaining a permit from the Association. (3 pts.)
8. Live trees on Parkways and Pathways: No person shall plant or remove living trees on the Parkway or other Common Areas without first obtaining a permit from the Association. (9 pts.) Living trees on the Parkway may be reasonably trimmed by lot Owners, but only with consent of the Association and the Owner's neighbors. Any other pruning or trimming is prohibited. (3 pts.)
9. Obstructions across Parkway: No obstruction (planting, deck, fences, etc.) across the Parkway or Pathways obstructing pedestrian access is permitted. The Association may, in its sole discretion and without notice, remove any offending structure and bill the responsible property-Owner. (3 pts.)

10. Application for construction on the Parkway and Pathways requires a legal survey or other approved verification of the property lines sufficient to identify the location of the proposed improvement.

E. MISCELLANEOUS:

1. Ice Removal Devices

For purposes of this subsection, an ice removal device is any device which agitates the water during freezing weather preventing the normal formation of ice.

- a. Ice removal devices shall only be used for a limited amount of time pursuant to a permit issued by the Executive Director or Operations Manager of the Association which shall only be issued in the case of imminent danger to property. (6 pts)
 - b. Any person operating an ice removal device during the ice season shall operate same to restrict the open water to an area not to exceed twenty feet Lake side from the Dock or structure owned by the Operator. (6 pts.)
 - c. Any person operating an ice removal device during the ice season shall post at least two warning signs reading "OPEN WATER" in letters not less than six inches high, one on each side of the structure they are de-icing, so that the signs can be read from the Lake side. (3 pts.)
2. The posting boards on the Lake Lotawana entrance monuments are reserved for civic and community organization's notices only. Signs posted at these locations should be removed by the posting organization in a timely manner. No personal signs or advertisement are permitted.
3. Mobile, manufactured or modular homes are prohibited. (3 pts.)

F. SUSPENSION OF LAKE PRIVILEGES – SEE APPENDIX

G. APPEALS TO VIOLATIONS – SEE APPENDIX B

SECTION V: ENFORCEMENT

A. WATER PATROL ENFORCEMENT, CITATIONS, AND POINTS:

1. ENFORCEMENT of the Rules and Regulations set forth by the Lake Lotawana Association, Inc. shall be the responsibility of the Lake Lotawana Water Patrol, Executive Director and Operations Manager. All Operators of Watercraft and persons using any Common Area shall follow instructions from Water Patrol or other authorized personnel.
 - a. All Watercraft shall yield the right-of-way to an authorized patrol Boat, utilizing a siren or flashing light, or otherwise signifying the existence of an emergency or a violation of the Lake rules,. (3 pts.)
 - b. The driver of any Watercraft involved in an accident involving injury or property damage shall immediately report the details of the accident including names, telephone numbers and any other relevant information concerning the incident to the Lake Lotawana Association Office or to the Lake Lotawana Water Patrol, and to the Police Department of the City of Lake Lotawana. Failure to make this report shall constitute a violation of the rules. (6 pts.)
 - c. All persons shall comply with the directions or orders of the Water Patrol or other authorized personnel. Failure to do so will constitute a violation meriting imposition of points. (6 pts.)
 - d. No person shall threaten the Water Patrol personnel with abusive language and/or physical harm. (12 pts. and suspension of Lake privileges.)

2. CITATIONS:

The Water Patrol, Operations Manager or Executive Director of the Lake Lotawana Association may issue a citation for any violation of these rules. All citations shall be directed against the property Owner, Renter, or Lessee, including citations of that person's children and guests. A duplicate of the citation shall be mailed to the responsible property Owner, Renter, or Lessee, at the address on file at the Association Office.

3. ACCUMULATION OF POINTS:

- a. Citations issued by the Lake Lotawana Association, Inc. shall designate the number of points assigned to the violation(s) cited.

- b. Violation of any section where points are not specified shall be a 3 point offense per diem.
- c. Continued non-compliance with the “Regulations” or the “Covenants and Restrictions of the Corporation Warranty Deeds”, shall result in the assessment of one (1) additional violation point per day for each violation not corrected within thirty (30) days of notice.
- d. Violations of any rules or regulations by a Renter or Lessee shall result in assessment of Violation Points to such Renter or Lessee.

B. SUSPENSION OF LAKE PRIVILEGES – (See Appendix B)

C. APPEALS TO VIOLATIONS – (See Appendix B)

APPENDIX A

Pontoon

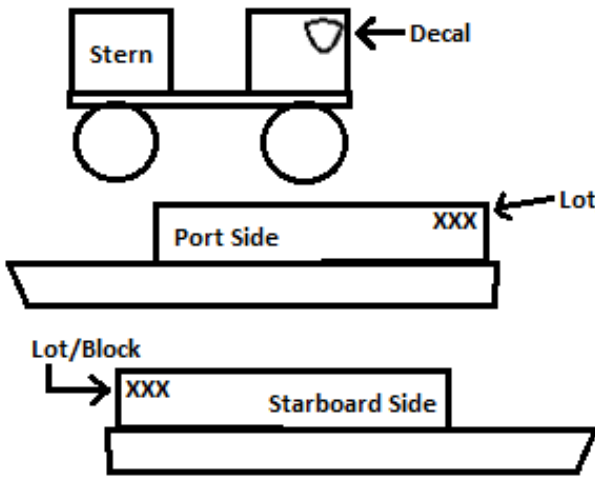

Power Craft

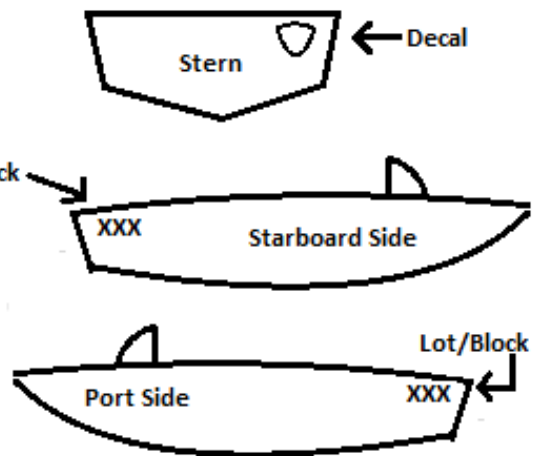

Stand-Up PWC



PWC



(1 Decal on Each Side)

Sailboat

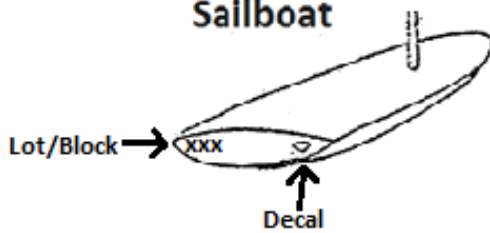

Canoe

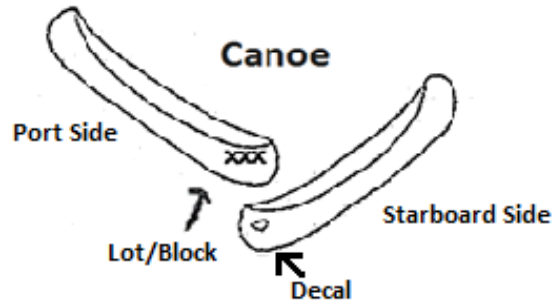

Paddle Boat

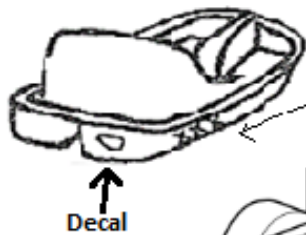

Kayak

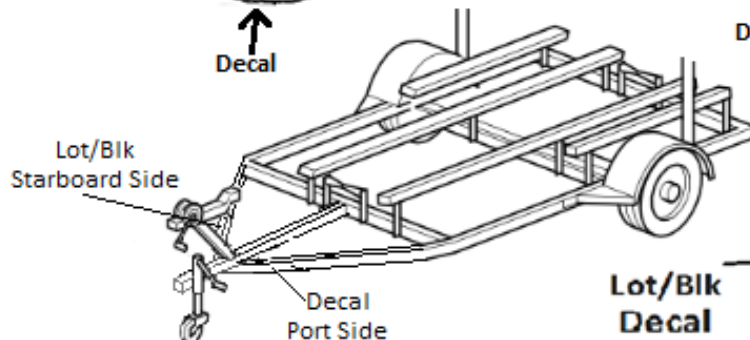
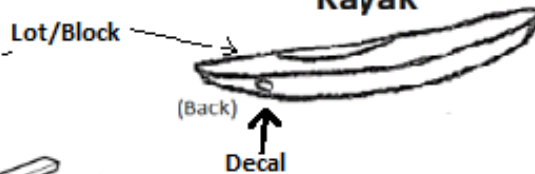

Paddle Board

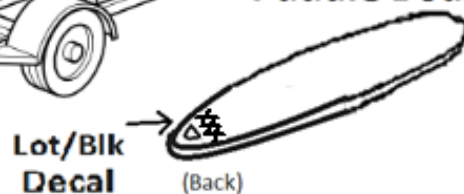

APPENDIX B:

A. SUSPENSION OF LAKE PRIVILEGES:

1. SUSPENSION OF LAKE PRIVILEGES:

Points assessed against a property Owner, Renter or Lessee, shall remain in effect for one year from the date of assessment. The property Owner, Renter or Lessee shall be suspended from using his or her Lake privileges, along with members of Family and guests whenever the points assessed during a 12 month period accumulate based on the following:

9 Points-- suspended for a period of up to fourteen (14) days
12 Points – suspended for a period of up to twenty-eight (28) days
15 Points – suspended for a period of up to twelve (12) months

2. Staff shall advise the Water Use Enforcement Board (WUEB) whenever points accumulate in evidencing a violation of the limits described above.
3. Upon receipt of notice from Staff of a potential point accumulation violation, the WUEB shall notify the property Owner and lessor, if any, of the potential violation and of the hearing date, by First-Class and Certified mail at the address on file at the Association Office; the notice will be mailed 7 days in advance of said meeting.
4. The Owner or Lessor shall be afforded the opportunity to review all documents relating to the suspension, and further to appear and present evidence at the WUEB meeting. Once the WUEB has closed its fact finding hearing, it may retire privately to vote on suspension. Any decision to suspend Lake privileges shall be decided by *at least* a 75 percent vote of a quorum of the WUEB.
5. Within 7 days of the meeting, the WUEB shall deliver a written decision by First-Class and Certified mail, to the property Owner, Renter or Lessee at the address on file at the Association office.
6. The Owner or Lessor may appeal the WUEB decision as provided in Section II herein. Once the appeal time runs without appeal, the decision of the WUEB shall be final and be deemed the action of the full Board of Directors.
7. A violation of suspension can result in trespass charges against and criminal prosecution of the violator, as well as further suspension of Lake privileges, as determined by the Water Enforcement Board.

8. Any person whose privileges are suspended shall take and pass a written, closed book test with 80% accuracy or better before privileges will be restored.

B. APPEALS OF VIOLATIONS:

1. DECISIONS AND SUSPENSIONS:

All appeals shall be made to an Appeals Board, composed of a quorum of Association Directors, at a regular or properly called Board of Directors meeting. Appeals shall be made in writing to the Association Office no later than 14 days after the citation or suspension is issued. The Board of Directors shall inform the applicant of the Board's decision to hear the appeal. The property Owner, Renter, or Lessee shall be notified in writing, as to the date, time and place of the appeal; the notice shall be mailed 7 days in advance of the appeal meeting.

2. Appeals before the Board of Directors shall be informal. The complainant and witnesses (if any) shall be heard first, followed by the alleged violator or property Owner, Renter or Lessee. Within 7 days following the appeal, the Board of Directors, by a majority vote, shall render a written decision, to be delivered by First-Class and Certified mail, to the property Owner, Renter or Lessee, at the address on file at the Association Office. All decision of the Appeals Board shall be final.

APPENDIX C:

Lake Lotawana Ski Club Jump Rules

A. Eligibility:

All jumpers and drivers must be current members of the Lake Lotawana Ski Club and be approved by the Ski Club to use the jump.

Safety:

1. All jumpers must wear a jump helmet, life jacket, and proper jump skis.
2. The gate must be returned to its full upright position and locked when jumping is completed.
3. Flashing Light will be attached to the jump to warn other Boaters of the jump at night.
4. All jumpers must follow Association rules regarding Water Skiing, i.e., There must be an observer in the Boat and ski flag requirements.

B. Jumping Times:

1. Jumping will only be allowed during times approved by the Lake Lotawana Association for Lake Lotawana Water Ski Club scheduled practices and show.
2. The jump will be put away by the last day in August.
3. Water Patrol may suspend jumping, if they determine that the congestion creates unsafe conditions.

C. Position of Jump:

1. Approximately 150 yards from the Yacht Club
2. Jumpers and drivers are reminded to use good judgment when jumping. Failure to follow these rules will result in loss of jump use.

APPENDIX D:

Ski Club Slalom Course Rules

A. Eligibility:

1. All Property Owners or Tenants of Lake Lotawana with paid Homeowners Association Dues displaying a Lake Lotawana Boat Sticker.

B. Safety:

1. All Skiers will wear a life jacket and a proper slalom ski.
2. All skiers must follow Association Rules regarding Water Skiing, i.e.: There must be an observer in the Boat and proper ski requirements.

C. Position of Slalom course:

1. The course shall run parallel to, within safe distance from, and approximately centered upon the dam until deemed necessary by the Board of Directors of the Homeowners Association to move it.

D. Slalom Course Times:

1. The course may only be set up from Monday A.M. until the following Thursday P.M. It will not be allowed on the Lake for the weekends, without expressed permission by the Homeowners Association Board of Directors.
2. Normal Association Rules regarding times for Lake use are in effect.

E. Rules for Use:

1. The course is to be used for slalom skiing only.
2. The use of any other water apparatus of but not limited to double-skis, wake boards, wake skates, knee boards, tubes, air-chairs or any other apparatus IS NOT ALLOWED THROUGH THE COURSE AT ANY TIME.
3. No Watercraft shall run through or parallel to the course without a slalom skier being pulled behind it. Please respect the space required of competition slalom skiing. Previously established safe Boating/skiing rules and appropriate points assessments will govern over the use of the course and monitored and enforced by Water Patrol. Any violations of these rules for use will result in 3 points.

Points of contact for the slalom course are: Sarah Frashier 578-4126 and Aaron Custer 578-2216

APPENDIX E SHARED DOCK AGREEMENT

This Agreement, entered into this _____ day of _____, 20____, between _____ and _____, as co-Owners of a Dock assigned to Lots _____ shall constitute the terms of use regarding the Dock space to be shared by said individuals. These terms and not exhaustive and may be altered or amended by the Parties, if approved by the Lake Lotawana Association. These terms and not exhaustive and may be altered or amended by the Association at any time. The following shall govern the use of any Dock shared between two or more property Owners:

1. Owners will be responsible for the maintenance and/or repair of the shared Dock in accordance with their Ownership rights. The Owner of each property shall be responsible for the costs of maintaining or making any necessary repairs. However, if it is alleged that any such need for repair is due to the acts and/or omissions of one of the Owners, then such Owner shall be solely responsible for such repair. If an agreement cannot be reached by the co-Owners within a reasonable amount of time (not to exceed 60 days) regarding fault and/or payment for repair of any damage to the Dock, the parties may bring their case to the Lake Improvement Board of the Lake Lotawana Association, who will then have final say in the matter.

2. Each Owner of a Dock shall have equal rights to the use and enjoyment of said Dock space. Each Owner shall have the right to allow friends and Family members who do not reside at the Lake to use and enjoy Dock privileges, but such right does not extend to the use of individuals who do not own property in Lake Lotawana to use the Dock at any time in which the Dock Owner is not present. Without any exceptions, no Boat may be Docked on Lake Lotawana that does not belong to a property Owner and/or is not registered with the Association.

3. Each party to this agreement will indemnify and hold the other Owner and the Lake Lotawana Association, Inc. harmless for any injury, loss, damage, cause of action, or claim resulting from any and all acts or omissions of the party, his agent, guest or other persons or entities on or utilizing the premises at the party's request. All Owners must carry and show proof of liability insurance Covering any Owners use and the use of any authorized individuals.

4. A Dock co-Owner shall make no changes or modification that would require approval from the Lake Lotawana Association Inc. to any portion of their Dock without prior written agreement with the other Owner.

5. The parties to this agreement shall keep his Dock clean and free of any impediment (boxes, lockers, ice chest or any personal property). Each party must keep the Dock in a reasonably safe condition and ensure the Dock does not present a safety risk.

6. Each co-Owner of a Dock shall use his slip or any other area of the Dock for the purpose intended and only for the size and character of their Boat suited to their slip.

Signatures of shared dock owners:

Signature Lot/Block Signature Lot/block

APPENDIX F HOLIDAY LAKE USE RULES

The following special rules are a codification of rules contained in the general rules that are specifically applicable to use of the Lake on the described holidays:

- A.** These rules shall apply to the following holidays from 6 p.m. the night before until midnight of the stated holiday: Memorial Day, Fourth of July, and Labor Day.
- B.** PWC: PWC use is restricted to the hours of 2 p.m. until ½ hour after sunset or 100 yards of visibility, whichever shall come first. III(M)(2)(m)
- C.** The Water Patrol may in their sole discretion curtail skiing during periods of heavy Watercraft traffic. III(N)(1)(c)
- D.** Skiing shall be permitted only during the following hours: Sunrise to 10:00 a.m. and 12:00 noon to 2:00 p.m. III(N)(3)(b)
- E.** Wake surfing is not allowed on the described holidays. III(N)(f)(6)
- F.** No person shall operate a sailboat in an organized or scheduled racing competition that starts before 8:00 a.m. or after 12:00 noon. III (Q)(12)